

Flat Roller Cage

FT

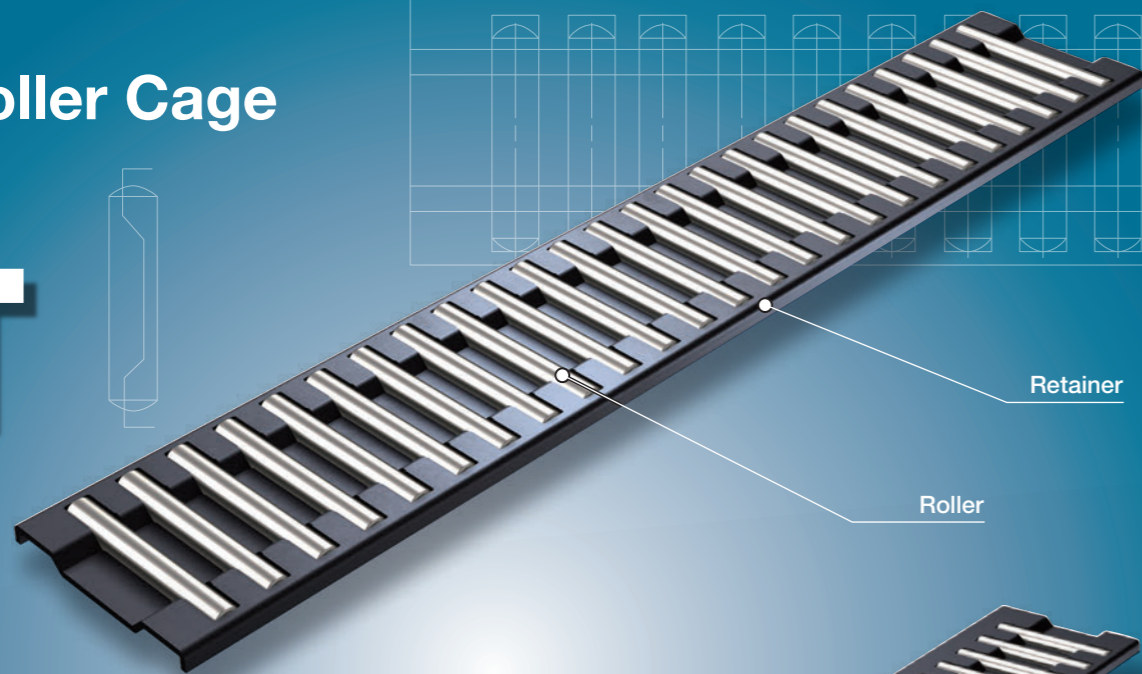

FTW...A

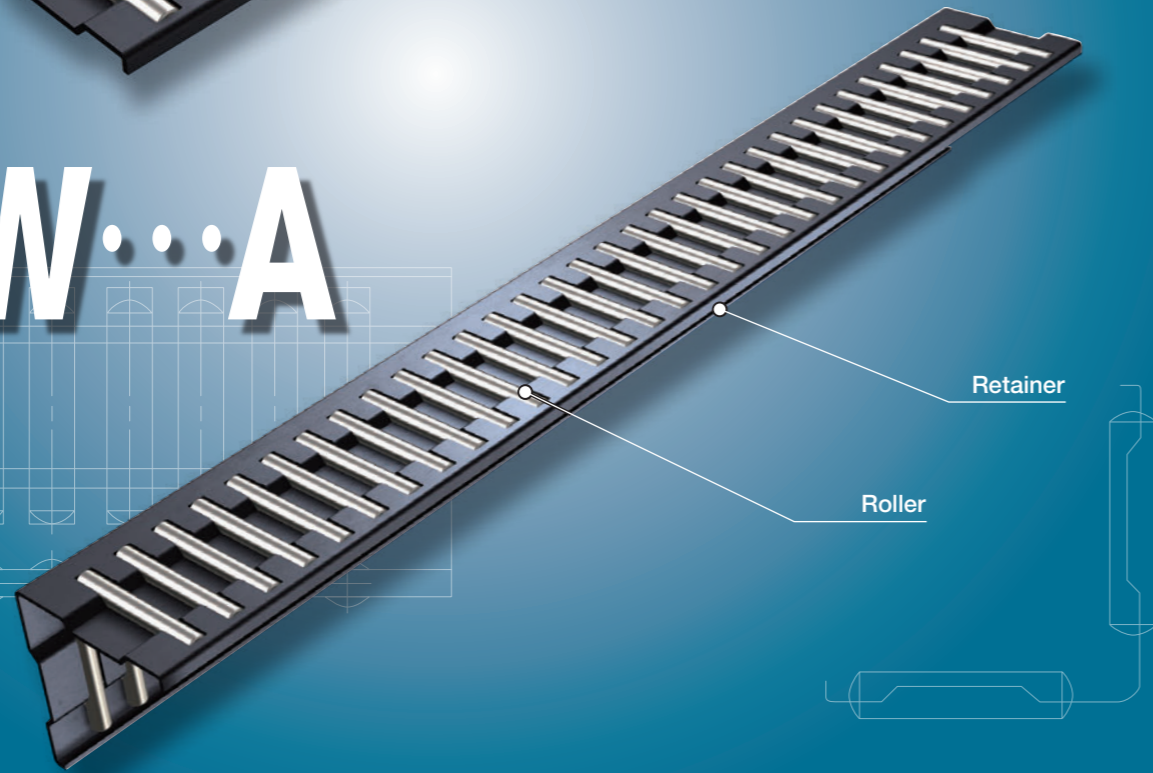

Points

1 Low section

Flat Roller Cage is a limited linear motion guide consisting of high accuracy rollers and a very precise retainers and features low cross sectional height which is as high as the roller diameter.

2 Large load rating

Rollers are assembled in a cage with a small pitch distance, so load ratings are large and the rigidity is high.

3 Simple replacement for rolling guide

A single row model and a double row model with a 90° are standardized and can be easily used to modify the conventional plain guide ways of machine tools, etc. into a rolling guide type without a large-scale redesign of the bed.

4 Smooth operations and low noise

As a retainer processed with high accuracy guides the rollers, the frictional resistance is very low without stick-slip, and stable linear motion is obtained. Retainers made of synthetic resin are most suitable for applications where low noise is required.

5 Easy handling

The rollers are caged in a retainer securely, allowing easy handling.

Identification Number and Specification

Example of an identification number

The specification of FT and FTW...A are indicated by the identification number. Indicate the identification number, consisting of a model code, dimensions, a supplemental code, and a selection code for each specification to apply.

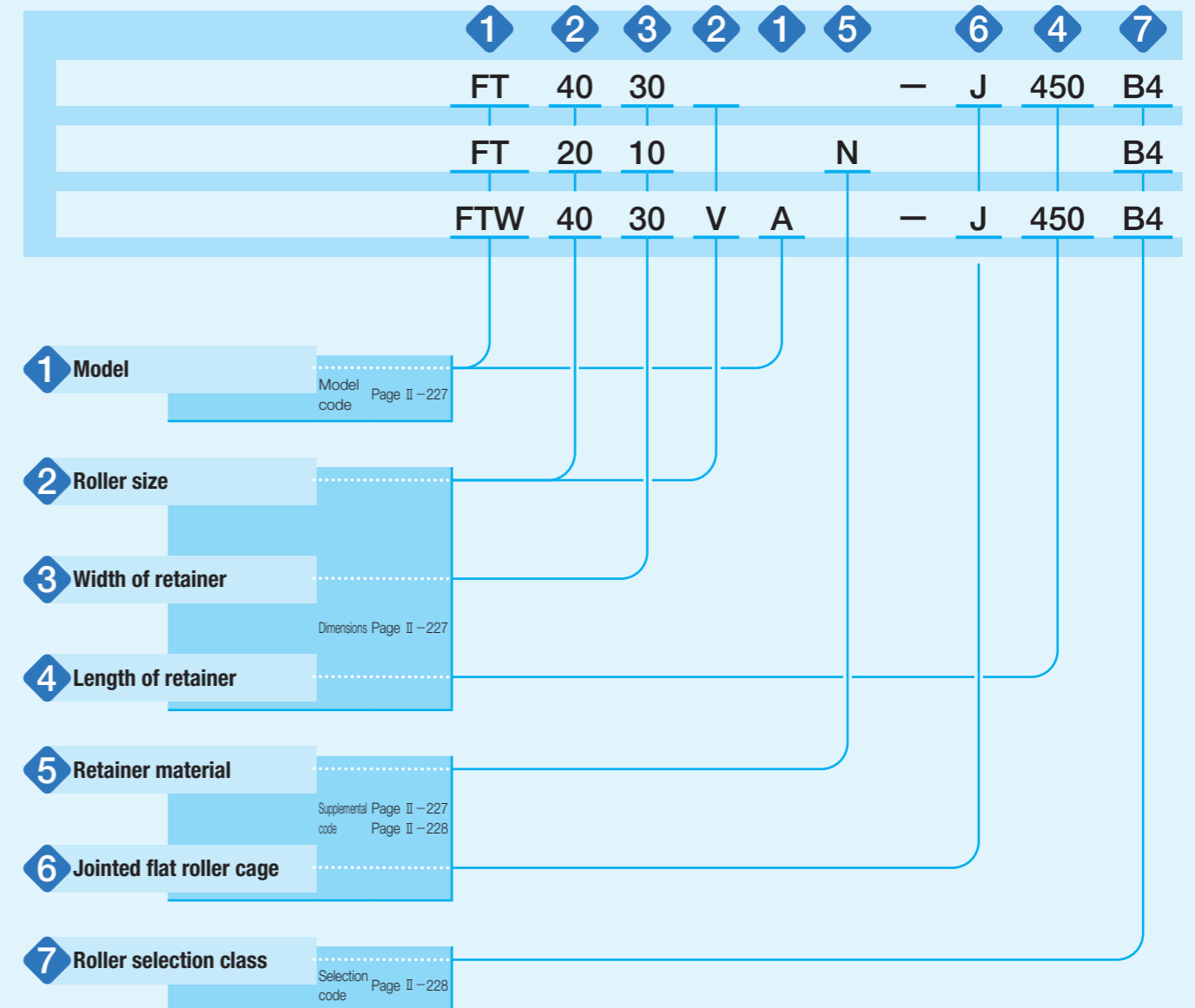

RW · SR · GSN
FT · FTW...A

Identification Number and Specification - Model · Roller Size · Width of Retainer · Length of Retainer · Retainer Material -

1 Model	Flat Roller Cage	Single row type	: FT
		Double row angle type	: FTW...A
For applicable models and roller sizes, see Table 1.			

2 Roller size	Indicate 10 times as large value as the roller diameter (mm).
	Indicate $10\sqrt{2}$ times as large integer value as roller diameter (mm) for those with code V.

Table 1 Models and sizes of FT and FTW...A

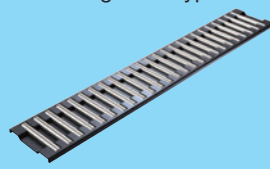
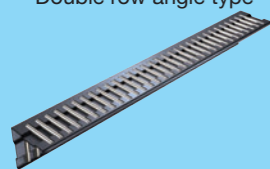
Shape	Retainer material	Model	Roller size							
			20	25	30	35	40	50	100	200
Single row type 	Steel made	FT	○	○	○	○	○	○	○	○
	Synthetic resin made	FT...N	○	○	○	○	-	-	-	-
Double row angle type 	Steel made	FTW...A	-	-	-	-	○	○	○	○

3 Width of retainer	Indicate the width of retainer in mm.
----------------------------	---------------------------------------

4 Length of retainer	Indicate the length of retainer in mm. Length other than the standard length stated in the dimension table can be prepared upon request. Contact IKO for further information.
-----------------------------	--

5 Retainer material	Steel made	: No symbol	Specify the retainer material.
	Synthetic resin made	: N	For applicable models and roller sizes, see Table 1.

- Jointed Flat Roller Cage · Roller Selection Class -

6 Jointed flat roller cage	Standard length retainer	: No symbol	Indicate full length of the retainer as well and specify ones longer than the standard length.
	Jointed flat roller cage	: J	

Flat Roller Cage with extended full length can be produced by connecting steel made retainers each other. If needed, please specify a retainer full length in mm after the supplemental code "J" following the way indicated in the example of an identification number. Maximum length of a jointed flat roller cage is indicated in Table 2. Length longer than the maximum stated in Table 2 can be prepared upon request. Contact **IKO** for further information.

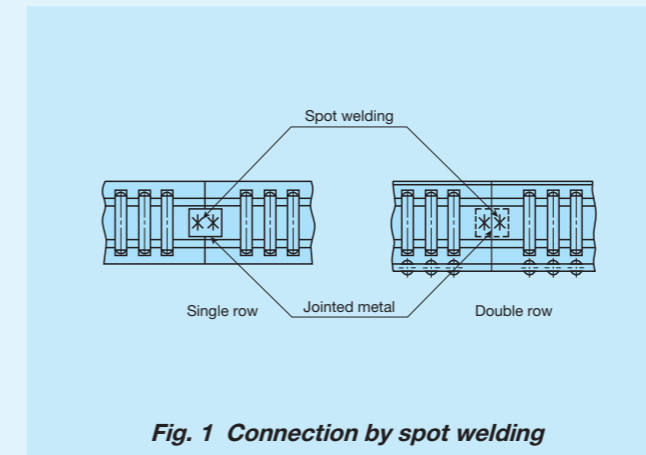

Fig. 1 Connection by spot welding

Table 2 Maximum length of jointed flat roller cage unit: mm

Identification number	Maximum length of retainer
FT 2010	300
FT 2515	
FT 3020	
FT 3525	375
FT 4030	
FT 4035	600
FT 4026 V	
FT 5038	1 000
FT 5043	
FT 5030 V	
FT 10080	
FT 10060 V	
FT 200120	
FT 200100 V	1 000
FTW 4030 VA	
FTW 5045 A	1 000
FTW 5050 A	
FTW 5035 VA	
FTW 10095 A	1 500
FTW 10070 VA	
FTW 200150 A	
FTW 200120 VA	

7 Roller selection class	For roller selection classes and tolerances of dimensions for roller diameters, see Table 3.
---------------------------------	--

Tolerances of dimensions for roller diameters are indicated in Table 3. Normally, one of the standard selection classes is delivered. To achieve accurate load distribution, it is necessary to combine products with the same selection code. If needed, please specify it following the way indicated in the example of an identification number.

Table 3 Roller selection class unit: μm

Selection class	Selection code	Average tolerances of dimensions for roller diameters ⁽¹⁾
Standard	B2	0 ~ -2
	B4	-2 ~ -4
	B6	-4 ~ -6
	B8	-6 ~ -8
Semi-standard	A1	0 ~ -1
	A2	-1 ~ -2
	A3	-2 ~ -3
	A4	-3 ~ -4
	A5	-4 ~ -5
	A6	-5 ~ -6

Note ⁽¹⁾ Allowance of roundness and cylindricity follows JIS B 1506:2005 roller bearing - roller.

Precaution for Use

① Raceway

Recommended values for surface hardness and roughness of mating raceway are shown in Table 4 and the recommended value for the minimum effective hardening depth is shown in Table 5.

Table 4 Surface hardness and roughness of raceway

Item	Recommended value	Remark
Surface hardness	58~64HRC	When the surface hardness is low, multiply the load rating by hardness factor (1).
Surface roughness	0.2 μmRa or lower (0.8 μmRy or lower)	Where accuracy standard is low, around 0.8 μmRa (3.2 μmRy) is also allowed.

Note (1) For hardness factor, refer to Fig. 3 in page III-5.

Table 5 Minimum effective hardening depth of raceway
unit: mm

Roller diameter		Recommended value for minimum effective hardening depth
Over	Incl.	
—	3	0.5
3	4	0.8
4	5	1.0
5	8	1.5
8	10	2.0
10	14.142	2.5
14.142	20	3.5

② When used for bed surface and 90° V surface

After complete lapping as indicated in Fig. 2, mount FT to FTW...VA, or FT...V to FTW...A. Combination of Flat Roller Cage at this point is indicated in Table 6.

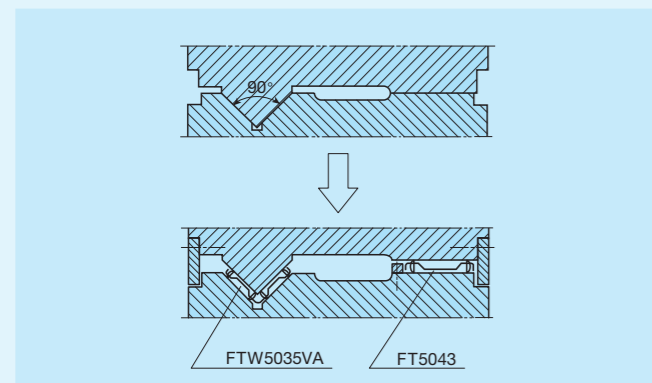

Fig. 2 Example of use on flat surface and 90° V surface

③ Stroke length and retainer length

Movement in a linear direction as in Fig. 3 will move the Flat Roller Cage in the same direction by one half of the movement amount. Therefore, way length, stroke length and retainer length are correlated as follows:

$$L_1 = \frac{S}{2} + L \dots\dots\dots(1)$$

where, L_1 : Way length, mm
 S : Stroke length, mm
 L : Retainer length, mm

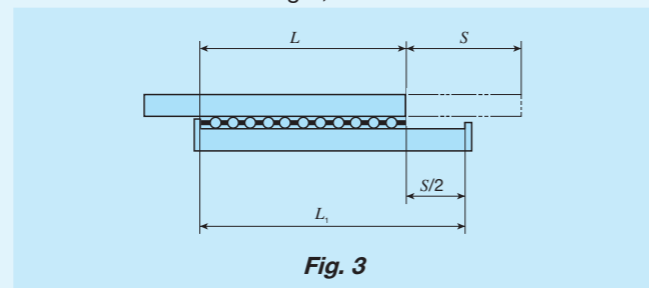

④ Operating temperature

If the retainer is made of steel, it can withstand higher temperature. However, if you use it in an environment exceeding 100°C, please contact **IKO**.

The retainer made of synthetic resin can withstand up to 100°C. For continuous operation, please keep it under 80°C.

Precaution for Mounting

FT and FTW...A are typically mounted as indicated in Fig. 4. When the heat-treated and polished way is mounted to the device body, you must be careful not to make deformation by tightening.

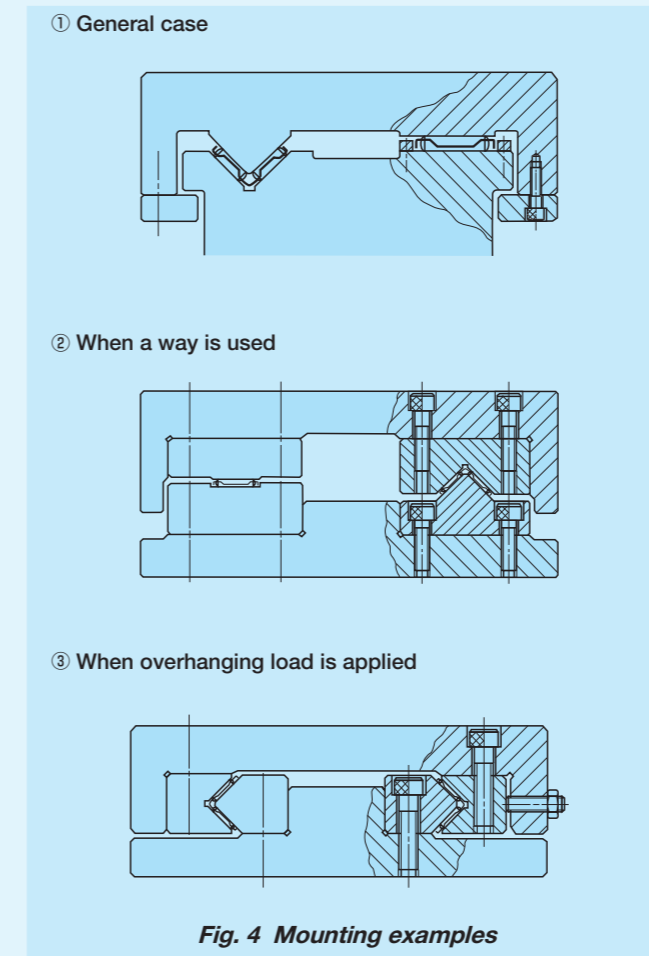

Fig. 4 Mounting examples

Table 6 Combination of Flat Roller Cage

Combination Number	For flat surface		For 90° V surface	
	Identification number	Roller diameter D_w	Identification number	Roller diameter D_w
1	FT 4030	4	FTW 4030 VA	2.828
2	FT 4035	4	FTW 4030 VA	2.828
3	FT 5038	5	FTW 5035 VA	3.535
4	FT 5043	5	FTW 5035 VA	3.535
5	FT 10060 V	7.071	FTW 5045 A	5
6	FT 10060 V	7.071	FTW 5050 A	5
7	FT 10080	10	FTW 10070 VA	7.071
8	FT 200100 V	14.142	FTW 10095 A	10
9	FT 200120	20	FTW 200120 VA	14.142

unit: mm

IKO Flat Roller Cage

Single row type Flat Roller Cage

Shape	FT			
Size	20	25	30	35
	40	50	100	200

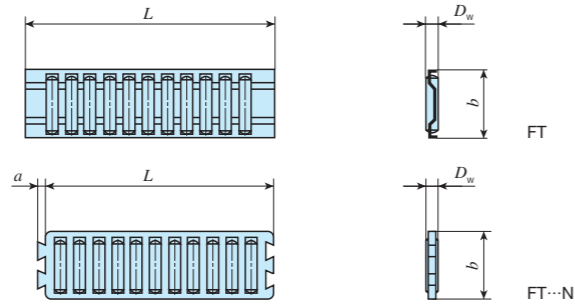

Double row angle type Flat Roller Cage

Shape	FTW...A			
Size	—	—	—	—
	40	50	100	200

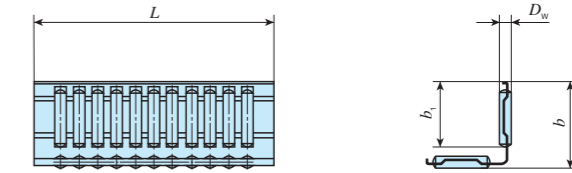

Identification number		Mass (Ref.) g	Nominal dimensions mm				Basic dynamic load rating C N	Basic static load rating C ₀ N
Steel retainer	Synthetic resin retainer		D _w	b	L	a		
—	FT 2010 N	1.63	2	10	32	2	8 660	19 800
FT 2010 - 32	—	1.91				—	9 710	22 900
FT 2010 - 100	—	5.8				100	22 900	68 700
—	FT 2515 N	4.3	2.5	15	45	2.5	17 300	41 100
FT 2515 - 45	—	5.6				—	22 000	56 200
FT 2515 - 100	—	11.6				100	37 900	112 000
—	FT 3020 N	9.7	3	20	60	3	31 600	78 800
FT 3020 - 60	—	12.5				—	37 100	96 700
—	FT 3525 N	18.6				3.5	51 400	132 000
FT 3525 - 75	—	23	—	58 400	155 000			
FT 4030 - 150	—	73	4	30	150	—	127 000	382 000
FT 4035 - 150	—	86		35		143 000	446 000	
FT 4026V - 150	—	45	2.828	26	150	—	97 300	347 000
FT 5038 - 250	—	195	5	38	250	—	267 000	851 000
FT 5043 - 250	—	200		43		306 000	1 020 000	
FT 5030V - 250	—	103	3.535	30	250	—	180 000	652 000
FT 10080 - 500	—	1 610	10	80	500	—	1 390 000	4 370 000
FT 10060V - 500	—	870	7.071	60	500	—	838 000	2 900 000
FT 200120 - 500	—	4 940	20	120	500	—	3 120 000	7 670 000
FT 200100V - 500	—	2 860	14.142	100	500	—	2 090 000	5 820 000

Identification number		Mass (Ref.) g	Nominal dimensions mm				Basic dynamic load rating C N	Basic static load rating C ₀ N
Steel retainer	Synthetic resin retainer		D _w	b	L	b ₁		
FTW 4030 VA - 150	—	94	2.828	30	150	24.5	118 000	491 000
FTW 5045 A - 250	—	410	5	45	250	35.5	332 000	1 240 000
FTW 5050 A - 250	—	460		50		40.5	371 000	1 440 000
FTW 5035 VA - 250	—	220	3.535	35	250	29	218 000	922 000
FTW 10095 A - 500	—	3 360	10	95	500	77	1 680 000	6 180 000
FTW 10070 VA - 500	—	1 790	7.071	70	500	56.5	1 020 000	4 110 000
FTW 200150 A - 500	—	10 200	20	150	500	118	3 790 000	10 800 000
FTW 200120 VA - 500	—	5 940	14.142	120	500	96	2 530 000	8 220 000