

## Roller Way & Flat Roller Cage

Roller Way  
Flat Roller Cage



# Roller Way

# RW

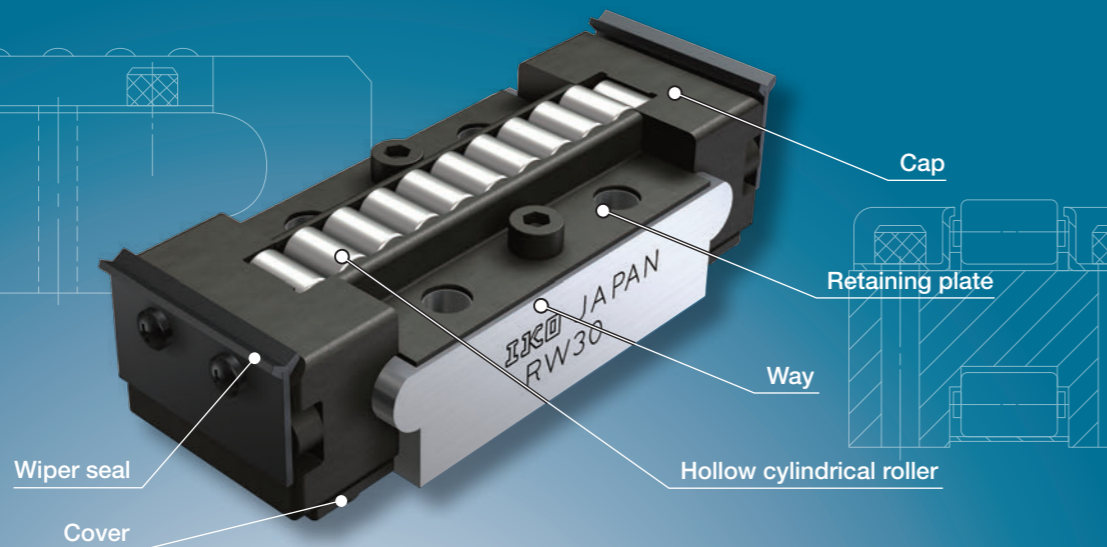

# SR

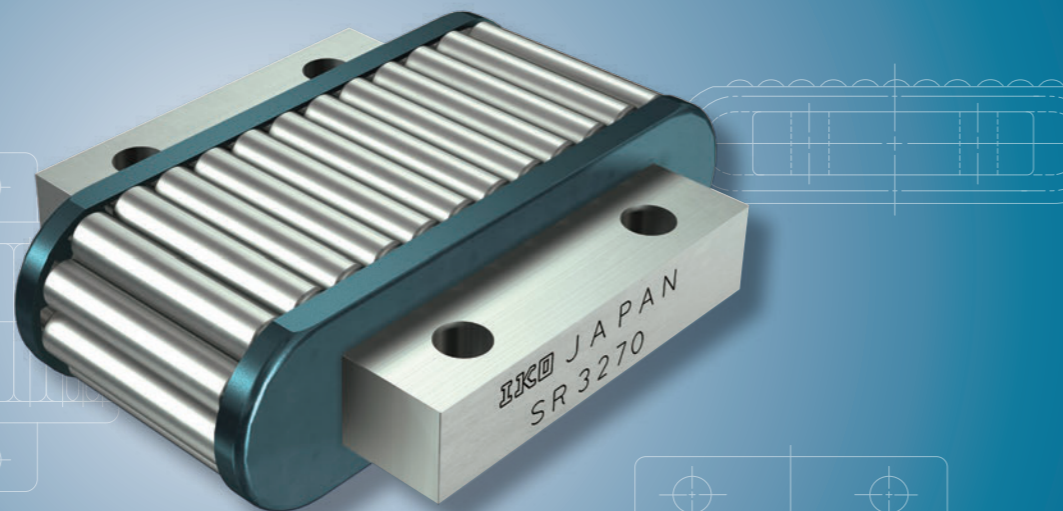

# GSN

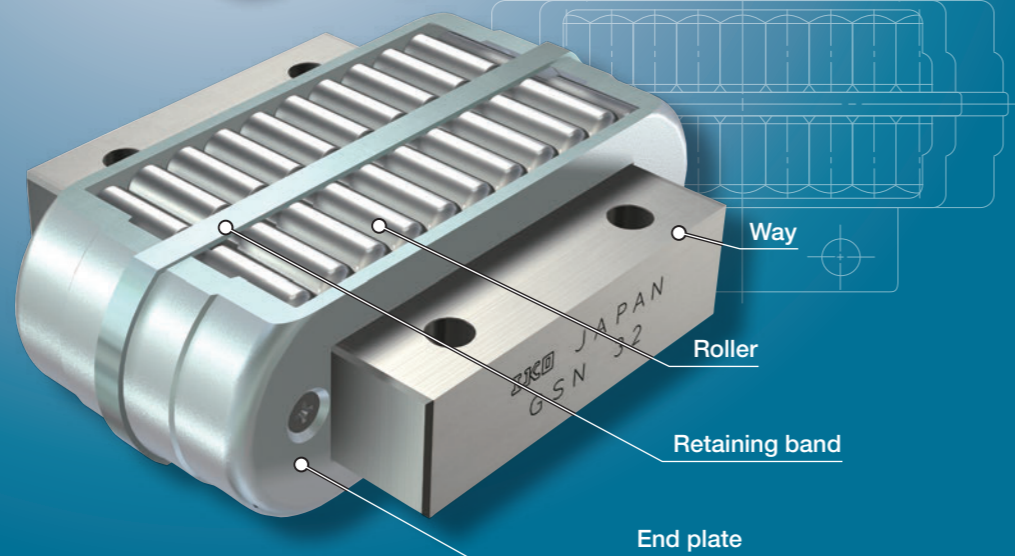

## Points

### 1 High rigidity and accuracy

Since the high accuracy roller is built into the highly flat surface way finished by accurate ground, the product has a high rigidity and high accuracy. Also because the variation of operation height can be selected in the unit of 2 μm, the load can be evenly distributed even in the multiple-use environment.

### 2 Smooth motion

The structure of all models lets the roller to be guided accurately without creating skew, yielding an extremely stable and smooth linear motion.

## Identification Number and Specification

### Example of an identification number

The specifications of RW, SR and GSN are indicated by the identification number. Indicate the identification number, consisting of a model code, dimensions, a part code, a classification symbol, and a selection code for each specification to apply.

	1	2	3	4	5
	RW	40	UU	SP	B4
	SR	2050		SP	B4
	GSN	20		SP	B4

1 Model Model code Page II-216

2 Size Dimensions Page II-216

3 Wiper seal Part code Page II-217

4 Accuracy class Classification symbol Page II-217

5 Selection class Selection code Page II-217

## Identification Number and Specification -Model · Size-

1 Model	Roller Way RW : RW Roller Way RW inch series : RWB Roller Way SR : SR Roller Way GSN : GSN
For applicable models and sizes, see Table 1.1 and Table 1.2.	

2 Size	Indicate the representative width in mm. For the inch series, indicate the width in the unit of 1/16 inch. For applicable models and sizes, see Table 1.1 and Table 1.2.
--------	--

RW · SR · GSN  
FT · FTW...A

Table 1.1 Models and sizes of RW, SR and GSN (Metric series)



Shape	Model	Size									
		15	20	25	26	30	32	40	50	70	95
	RW	-	-	-	○	○	-	○	○	○	○
	SR	○	○	○	-	-	○	○	○	-	-
	GSN	○	○	○	-	-	○	○	○	-	-

Table 1.2 Models and sizes of RWB (Inch series)

Shape	Model	Size					
		14	16	24	32	48	64
	RWB	○	○	○	○	○	○

**3 Wiper seal**

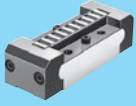
Without wiper seal	: No symbol	Applicable to Roller Way RW.
With wiper seal	: UU	Attach the wiper seal in the linear motion direction. This wiper seal is made of special synthetic rubber in double-lipped shape and has high removal performance against foreign substances.

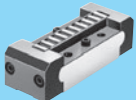
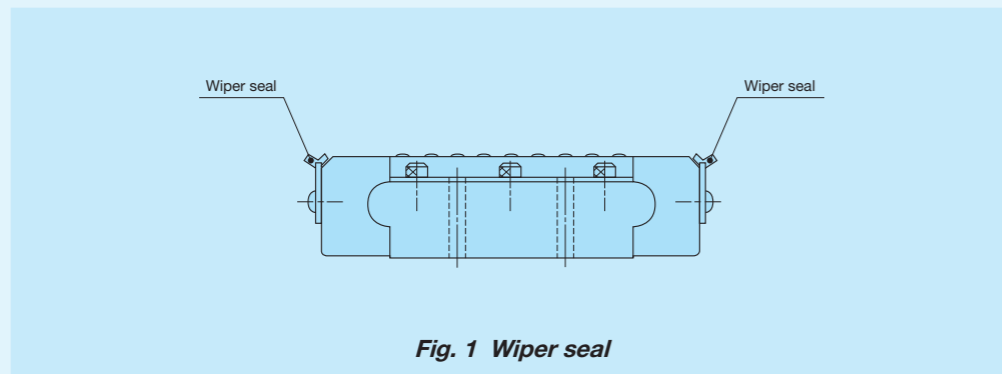

**4 Accuracy class**

Ordinary	: No symbol	For applicable accuracy class, see Table 2.1 and Table 2.2.
High	: H	
Precision	: P	For details of accuracy class, see Table 3.1, Table 3.2, and Table 4.
Super precision	: SP	

**5 Selection class**

When many are used on the same surface, it is required to use those with the same selection code from tolerances of dimensions in *H* of Table 4 to evenly distribute the load. When tolerances of dimensions of *H* is not specified, please specify a classification symbol only.

Table 2.1 Application of accuracy class of RW, SR and GSN (Metric series)

Size	Class (classification symbol)			
	Ordinary <sup>(1)</sup> (No symbol)	High (H)	Precision (P)	Super precision (SP)
15	○	○	○	○
20	○	○	○	○
25	○	○	○	○
26	-	○	○	○
30	-	○	○	○
32	○	○	○	○
40	○	○	○	○
50	○	○	○	○ <sup>(2)</sup>
70	-	○	○	-
95	-	○	○	-

Notes <sup>(1)</sup> Applicable to SR and GSN.  
<sup>(2)</sup> Applicable to RW.

Table 2.2 Application of accuracy class of RWB (Inch series)

Size	Class (classification symbol)			
	Ordinary (No symbol)	High (H)	Precision (P)	Super precision (SP)
14	-	○	○	○
20	-	○	○	○
24	-	○	○	○
32	-	○	○	○
48	-	○	○	-
64	-	○	○	-

Table 3.1 Tolerances of RW and RWB width *W*

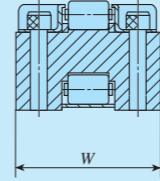

Size	RW		Size	RWB	
	Dim. <i>W</i> tolerance	mm		Dim. <i>W</i> tolerance	inch
26	0		14	0	
30	-0.05		16	-0.002	
40			24		
50	0		32	0	
70	-0.07		48	-0.003	
95	0		64	0	
	-0.10			-0.004	

Table 3.2 Tolerances of SR and GSN width *W<sub>1</sub>*, and length *L<sub>1</sub>*

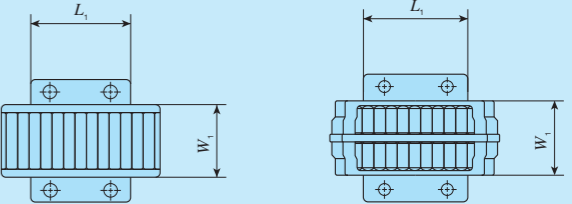

Size	Dim. <i>W<sub>1</sub></i> tolerance		Dim. <i>L<sub>1</sub></i> tolerance	
	mm	inch	mm	inch
15				
20	0		0	
25	-0.2		-0.2	
32				
40				
50	0		0	
	-0.3		-0.3	

unit: mm

Table 4 Selection code, and tolerance of height *H* and operation height *A*

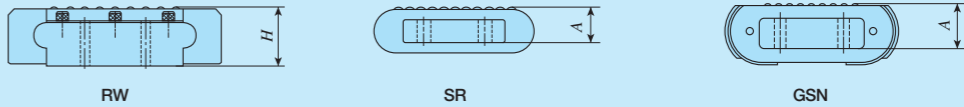

Item	Selection code	Dim. tolerance of height <i>H</i> and operation height <i>A</i>	
		Metric series mm	Inch series inch
Accuracy class			
Ordinary (no symbol)	-	0 ~ -0.010	-
High (H)	E 5	0 ~ -0.005	0 ~ -0.0002
	E 10	-0.005 ~ -0.010	-0.0002 ~ -0.0004
Precision (P)	C 3	0 ~ -0.003	0 ~ -0.00012
	C 6	-0.003 ~ -0.006	-0.00012 ~ -0.00024
	C 9	-0.006 ~ -0.009	-0.00024 ~ -0.00036
Super precision (SP)	B 2	0 ~ -0.002	0 ~ -0.00008
	B 4	-0.002 ~ -0.004	-0.00008 ~ -0.00016
	B 6	-0.004 ~ -0.006	-0.00016 ~ -0.00024
	B 8	-0.006 ~ -0.008	-0.00024 ~ -0.00032
	B 10	-0.008 ~ -0.010	-0.00032 ~ -0.00040



# Precaution for Use

## 1 Raceway

Recommended values for surface hardness and roughness of mating raceway are shown in Table 5 and the recommended value for the minimum effective hardening depth is shown in Table 6.1 and Table 6.2.

**Table 5 Surface hardness and roughness of raceway**

Item	Recommended value	Remark
Surface hardness	58~64HRC	When the surface hardness is low, multiply the load rating by hardness factor (1).
Surface roughness	0.2 μmRa or lower (0.8 μmRy or lower)	Where accuracy standard is low, around 0.8 μmRa (3.2 μmRy) is also allowed.

Note (1) For hardness factor, refer to Fig. 3 in page III-5.

**Table 6.1 Minimum effective hardening depth of raceway (RW and RWB) unit: mm**

Identification number	Recommended value for minimum effective hardening depth
RW 26    RWB 14	0.8
RW 30    RWB 16	1.0
RW 40    RWB 24	1.5
RW 50    RWB 32	2.0
RW 70    RWB 48	2.5
RW 95    RWB 64	3.0

**Table 6.2 Minimum effective hardening depth of raceway (SR and GSN) unit: mm**

Identification number	Recommended value for minimum effective hardening depth
SR 15    GSN 15	0.8
SR 20    GSN 20	1.0
SR 25    GSN 25	1.0
SR 32    GSN 32	1.5
SR 40    GSN 40	1.5
SR 50    GSN 50	2.0

## 2 Accuracy of mounting surface

For accuracy of mounting surface, values in Table 7.1 and Table 7.2 are recommended.

**Table 7.1 Accuracy of mounting surface (RW and RWB)**

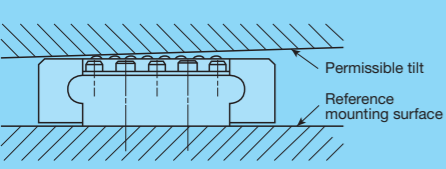
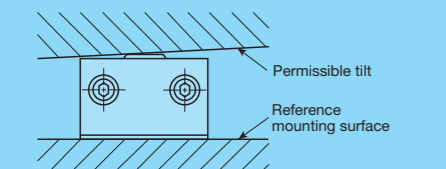
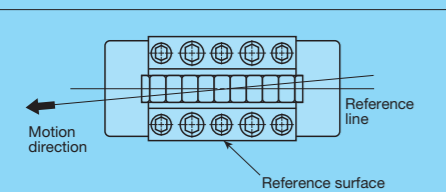
Item	Recommended value
	0.02/100 or lower
	0.015/100 or lower
	0.05/100 or lower

**Table 7.2 Accuracy of mounting surface (SR and GSN)**

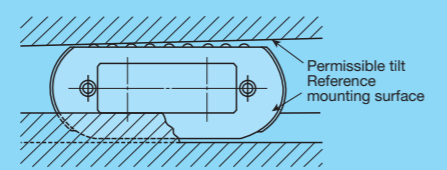
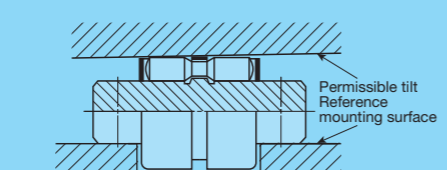
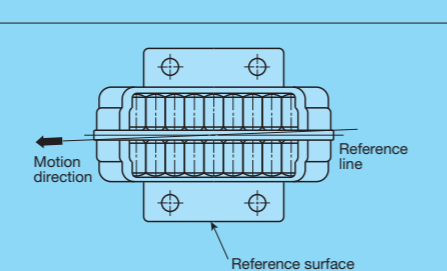
Item	Recommended value
	0.02/100 or lower
	0.015/100 or lower
	0.05/100 or lower

## 3 Groove machining on SR and GSN mounting surface

When mounting SR and GSN to the groove-machined mounting surface, the groove depth  $E$  should be deeper than the height from the bottom surface of the way to the bottom of the SR and GSN to provide clearance for oil pool. (See Fig. 2.)

Other than the above, groove width  $W$  corresponding to the width  $W_1$  for SR should be as wide as clearance fit and the relation between the clearance and the groove position on the reference surface side must be considered.

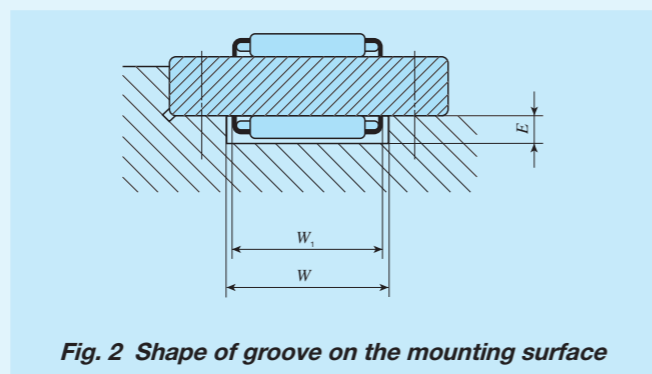

**Fig. 2 Shape of groove on the mounting surface**

## 4 Operating temperature

The maximum operating temperature is 120°C and temperature up to 100°C is allowed for continuous operation. When the temperature exceeds 100°C, contact **IKO**.

# Precaution for Mounting

## 1 Reference mounting surface

To mount RW, RWB, SR, and GSN in the linear motion direction, mount them by referring the opposite side of the **IKO** mark on the way end as reference surface. (See Fig. 3.) In addition, the surface under load is the upside of the **IKO** mark on the way end seen as the normal position.

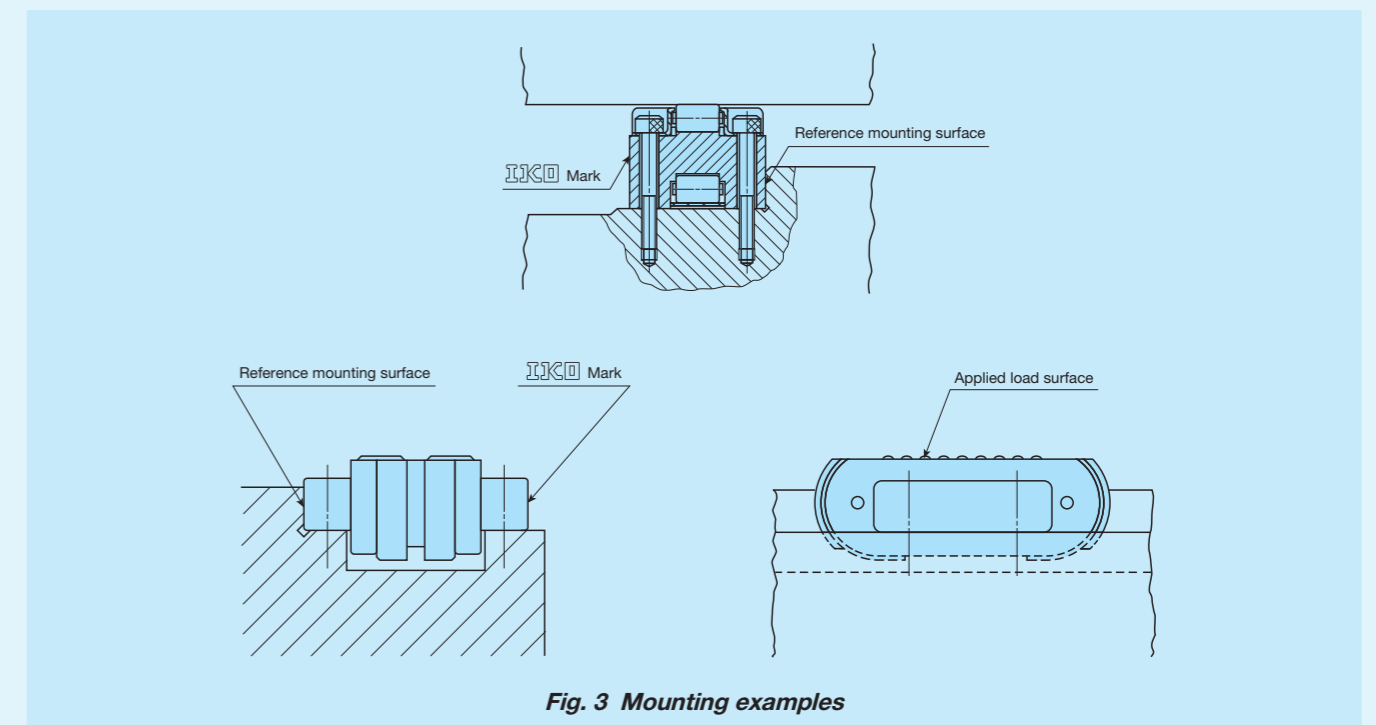

**Fig. 3 Mounting examples**

## 2 How to mount SR and GSN

To mount it, fix the way directly to a table or a bed with bolts, or fix it with pressure plate as indicated in Fig. 4. For SR, mounting with pressure plate is recommended.

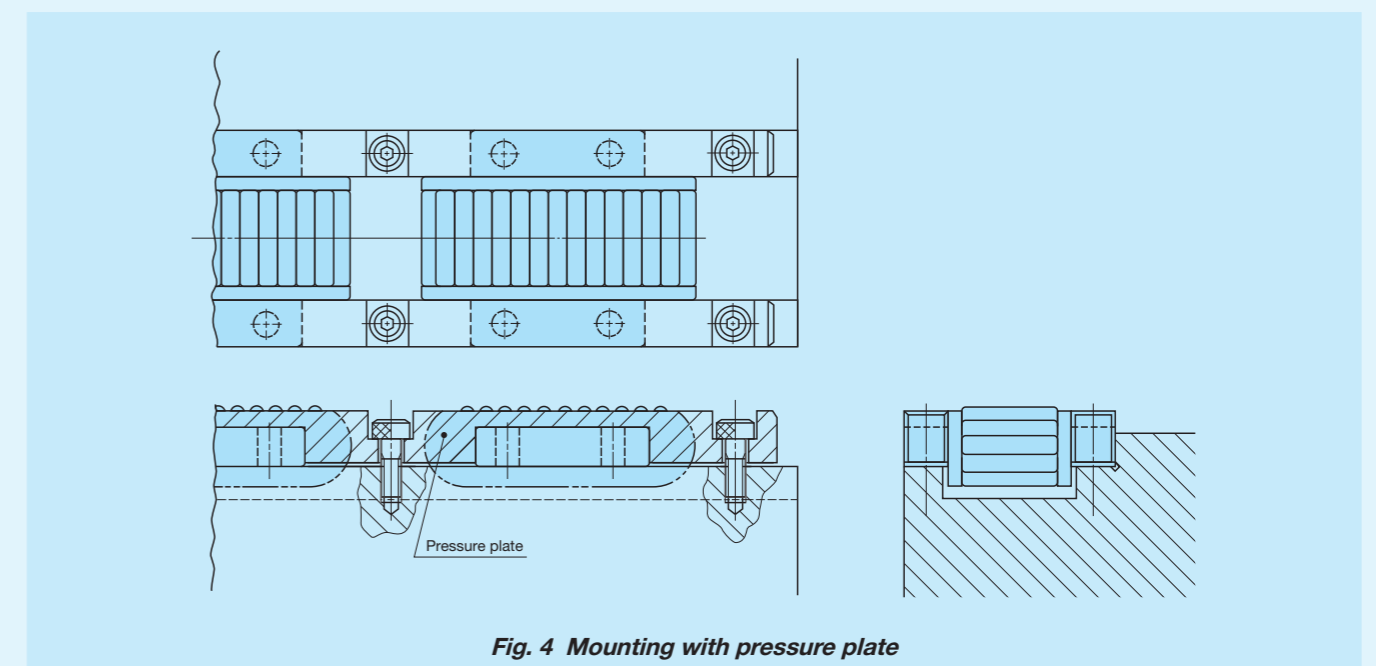

**Fig. 4 Mounting with pressure plate**

Shape	<b>RW</b>		
			
Size	26	30	40
	50	70	95

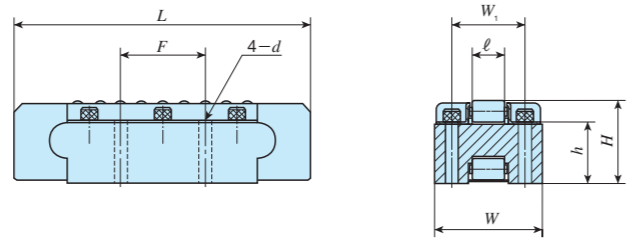

Identification number	Mass (Ref.) g	Nominal dimensions mm								Basic dynamic load rating C N	Basic static load rating C <sub>0</sub> N
		W	H	L	ℓ	F	W <sub>1</sub>	h	d		
RW 26	74	26	14	50	6	19	16	10	3.4	25 000	40 100
RW 30	179	30	19	70	7.5	25.4	19	14	4.5	39 800	71 200
RW 40	740	40	28	100	11.3	38.1	26	21	5.5	85 700	160 000
RW 50	1 750	50	38	140	15	50.8	35	28.5	6.6	154 000	314 000
RW 70	5 260	70	57	200	22.5	76.2	48	42.5	9.0	306 000	638 000
RW 95	12 700	95	76	270	30	101.6	65	56.5	11.0	514 000	1 130 000

Shape	<b>RWB</b>		
			
Size	14	16	24
	32	48	64

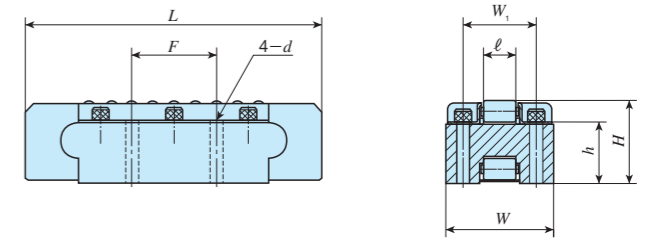

Identification number	Mass (Ref.) g	Nominal dimensions inch / mm								Basic dynamic load rating C N	Basic static load rating C <sub>0</sub> N
		W	H	L	ℓ	F	W <sub>1</sub>	h	d		
RWB 14*	91	7/8 22.225	9/16 14.288	1.97 50	0.236 6	3/4 19.050	43/64 17.066	0.41 10.4	0.125 3.2	25 000	40 100
RWB 16*	227	1 25.400	3/4 19.050	2.76 70	0.295 7.5	1 25.400	13/16 20.638	0.56 14.2	0.125 3.2	39 800	71 200
RWB 24*	730	1 1/2 38.100	1 1/8 28.575	3.94 100	0.445 11.3	1 1/2 38.100	1 7/32 30.956	0.85 21.5	0.180 4.6	85 700	160 000
RWB 32*	1 770	2 50.800	1 1/2 38.100	5.51 140	0.591 15	2 50.800	1 5/8 41.275	1.12 28.5	0.206 5.2	154 000	314 000
RWB 48*	5 670	3 76.200	2 1/4 57.150	7.88 200	0.886 22.5	3 76.200	2 7/16 61.912	1.68 42.8	0.266 6.8	306 000	638 000
RWB 64*	13 500	4 101.600	3 76.200	10.63 270	1.181 30	4 101.600	3 1/4 82.550	2.24 57.0	0.328 8.3	514 000	1 130 000

Remark: The identification numbers with \* are our semi-standard items.

Shape	<b>SR</b>		
			
Size	15	20	25
	32	40	50

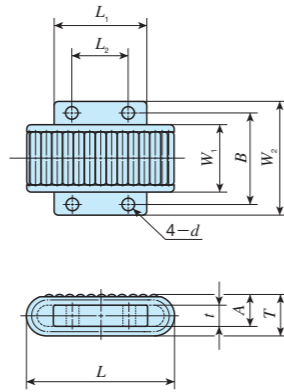

Shape	<b>GSN</b>		
			
Size	15	20	25
	32	40	50

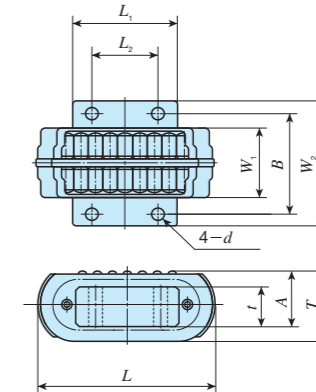

Identification number	Mass (Ref.) g	Nominal dimensions mm											Basic dynamic load rating C N	Basic static load rating C <sub>0</sub> N
		W <sub>1</sub>	W <sub>2</sub>	L	A	T	L <sub>1</sub>	L <sub>2</sub>	B	d	t			
SR 1540	62	15	30	40	11	15	20	12	23	3.3	7	26 500	45 900	
— GSN 15	82	15	30	40	15	20	19	12	23	3.4	11	22 300	36 000	
SR 2050	120	20	36	50	12	16	30	18	29	3.8	8	42 800	96 300	
— GSN 20	145	20	36	50	15	20	29	18	29	3.4	11	40 100	87 900	
SR 2560	210	25	45	60	14	19	35	20	36	4.8	9	67 300	156 000	
— GSN 25	260	25	45	60	18	24.5	35	20	36	4.5	13	58 900	131 000	
SR 3270	345	32	55	70	15	20	45	27	44	5.5	10	97 500	271 000	
— GSN 32	413	32	55	70	18	24.5	45	27	44	4.5	13	88 800	241 000	
SR 4090	750	40	68	87	21	28	55	35	54	6.5	14	143 000	373 000	
— GSN 40	940	40	68	92	25	34	54	35	54	5.5	18	133 000	337 000	
SR 50125	1 870	50	82	125	30	40	78	50	66	8.5	20	252 000	673 000	
— GSN 50	1 800	50	82	121	30	42	77	50	66	6.6	20	242 000	634 000	